

REV.	DESCRIPTION	DATE	DRAWN	APPROVED
A1	DWG.REL	2016/10/7	FANG	YANG

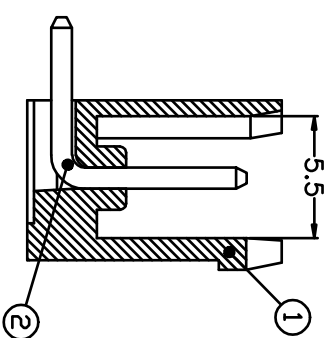
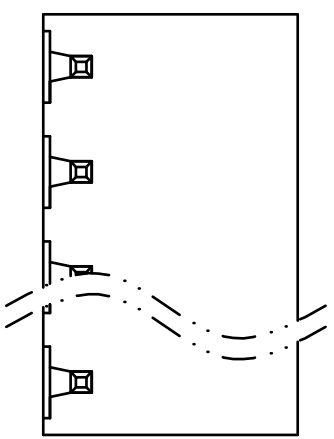
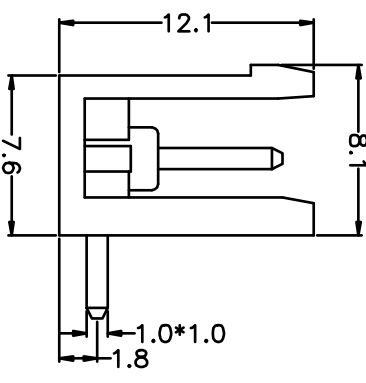
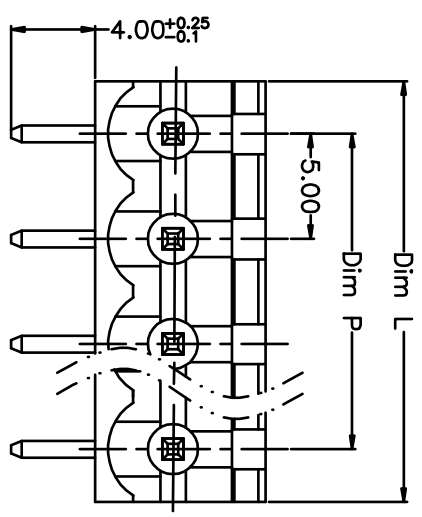

- Material  
 ①Housing : PA66, UL94V-0  
 ②Pin header : Brass, Tin plated
- Electrical  
 UL IEC  
 Rated voltage : 300V 320V  
 Rated current : 15A 20A  
 Insulation resistance: 500MΩ/DC500V  
 Withstanding Voltage : AC2000V/1min
- Mechanical  
 Operating temperature: -40°C~+105°C  
 Soldering temperature: 250°C±5/5sec

HOW TO ORDER

KF2EDGR-X-5.0-XXP-1 X-XXXXX

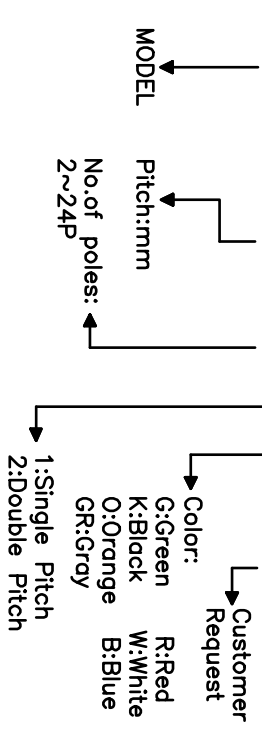

N=Number of Poles  
 Dim P=(N-1)x5.00  
 Dim L=Nx5.00

Poles	Dim P	Dim L
2-6P	±0.10	±0.15
7-12P	±0.20	±0.20
13-18P	±0.25	±0.30
19-24P	±0.30	±0.40

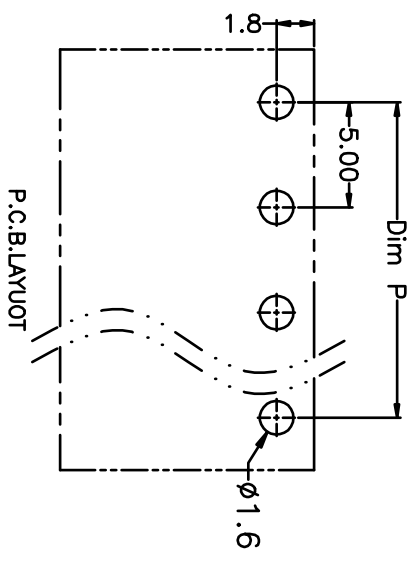

GENERAL TOLERANCE ANGLE TOLERANCE

X.	±0.5	X.	±5°
.X	±0.3	.X.	±3°
.XX	±0.1	.XX.	±1°

PROJECTION UNITS TITLE

SHEET SIZE	A4	SERIES	KF2EDGR-X
SCALE	1:1	SHEET	1 OF 1
DRAWING NO.	XP0012016-xxxx		

**凯峰电子有限公司**  
 KAIFENG ELECTRONIC CO.,LTD

CIXI KAIFENG ELECTRONIC CO.,LTD