

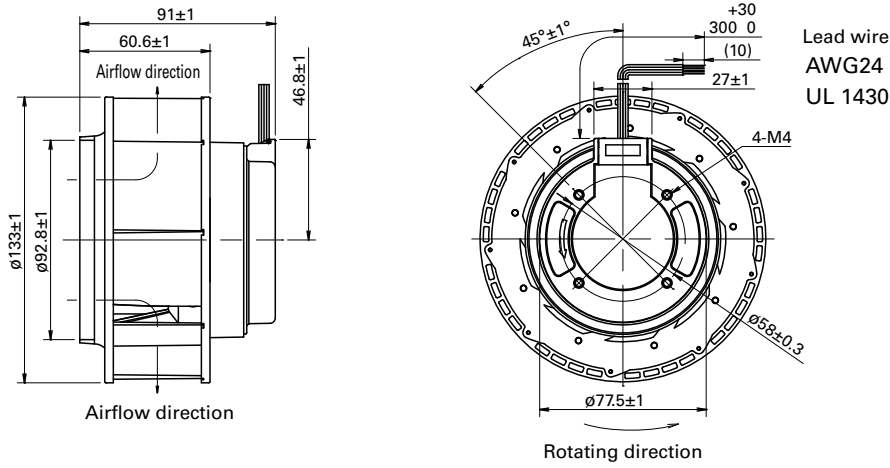

**Dimensions (unit: mm)**

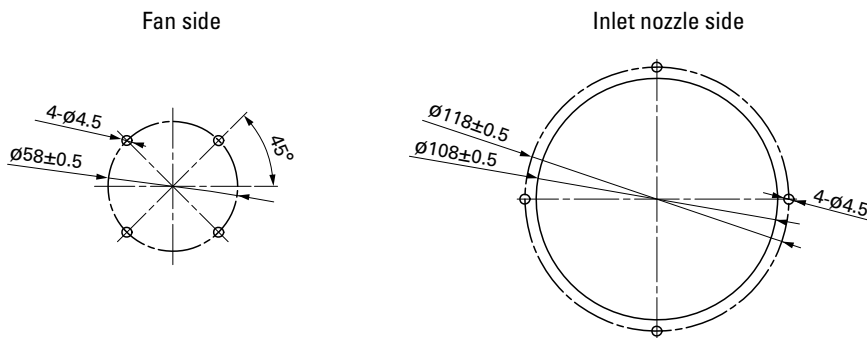

**Reference Dimensions of Mounting Holes and Vent Opening (unit: mm)**



**Reference Diagram for Mounting**

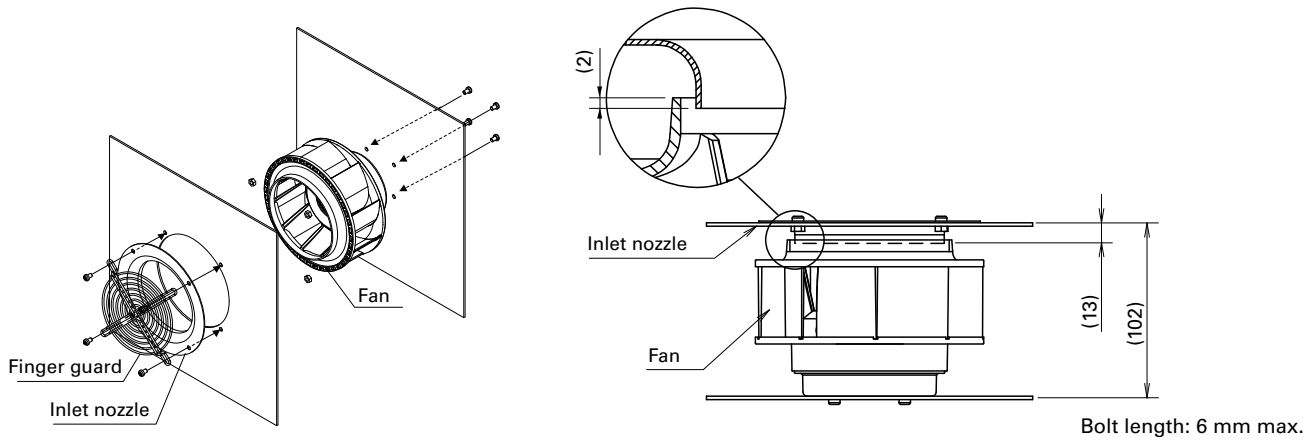

**Options**

Finger guards

page: p. 514

Model no.: 109-1112

Inlet nozzle

page: p. 518

Model no.: 109-1069, 109-1069H