

## PLASTIC UTILITY ENCLOSURE



### PRODUCT INFORMATION

#### MATERIAL:

- High impact ABS which is flame retardant to both UL94-V0 and UL94-HB.
- Available in White(RAL9002, UL94-V0 of ABS) or Black(RAL9005, UL94-HB of ABS).

#### FEATURES:

- Ideally design for portable , desktop or wall mounted electronic application.
- Space of the recessed area are designed for 4.3" , 5.7" , 7.0" , 8.4" & 10.4" lcd module or touch screen use.
- Lid & base incorporate a tongue and groove sealing design, optional EPDM gasket can be ordered and installed to meet IP65 rating of waterproof and dust.
- Recommended working temperature : -20°C to 80°C.
- Put-on rubber feet are included.



PL2943WH



PL2984BK

# PL29XXXWH, PL29XXXBK SERIES

## PL29XXXWH SERIES

ITEM No.	COLOR	MATERIAL	EXTERNAL DIMENSION(mm)		
			LENGTH	WIDTH	HEIGHT
PL2943WH	White	ABS, UL94-V0	140	100	30
PL2957WH	White	ABS, UL94-V0	190	150	30
PL2970WH	White	ABS, UL94-V0	221	161.5	30
PL2984WH	White	ABS, UL94-V0	279	206	30
PL29104WH	White	ABS, UL94-V0	322	232	30

External Dimension



PL2943WH  
size: 140X100X30MM

## PL29XXXBK SERIES

ITEM No.	COLOR	MATERIAL	EXTERNAL DIMENSION(mm)		
			LENGTH	WIDTH	HEIGHT
PL2943BK	Black	ABS, UL94-HB	140	100	30
PL2957BK	Black	ABS, UL94-HB	190	150	30
PL2970BK	Black	ABS, UL94-HB	221	161.5	30
PL2984BK	Black	ABS, UL94-HB	279	206	30
PL29104BK	Black	ABS, UL94-HB	322	232	30

External Dimension



PL2984BK  
size: 279X206X30MM

## Optional EPDM Gasket

ITEM No.	PRODUCT DESCRIPTION
PL2943GSKT	Φ2.3mm x 510mm EPDM Gasket.
PL2957GSKT	Φ2.3mm x 710mm EPDM Gasket.
PL2970GSKT	Φ2.3mm x 795mm EPDM Gasket.
PL2984GSKT	Φ2.3mm x 1000mm EPDM Gasket.
PL29104GSKT	Φ2.3mm x 1140mm EPDM Gasket.

Example EPDM gasket



Content



**PL2943WH / PL2943BK**

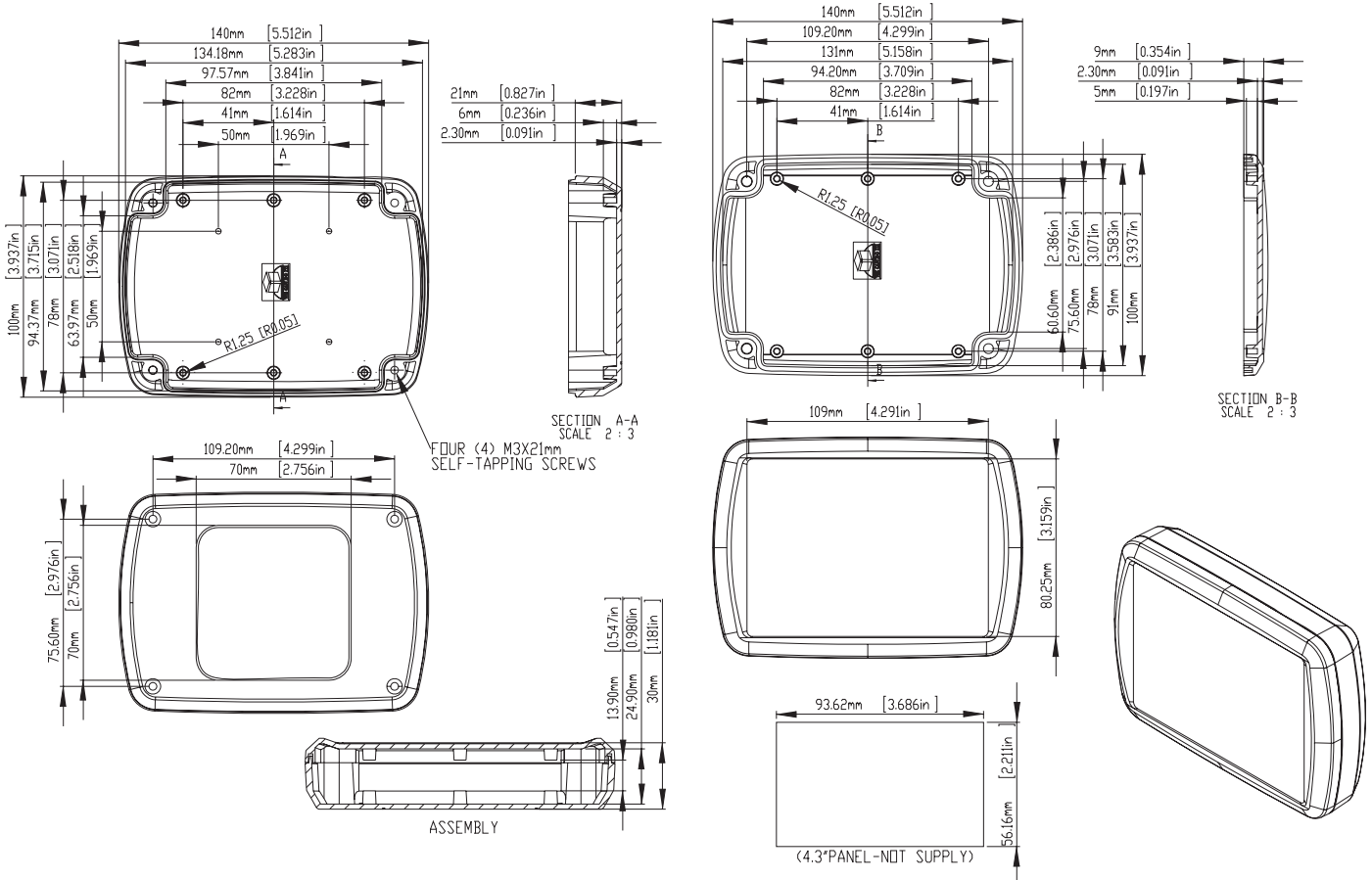

**PL2957WH / PL2957BK**

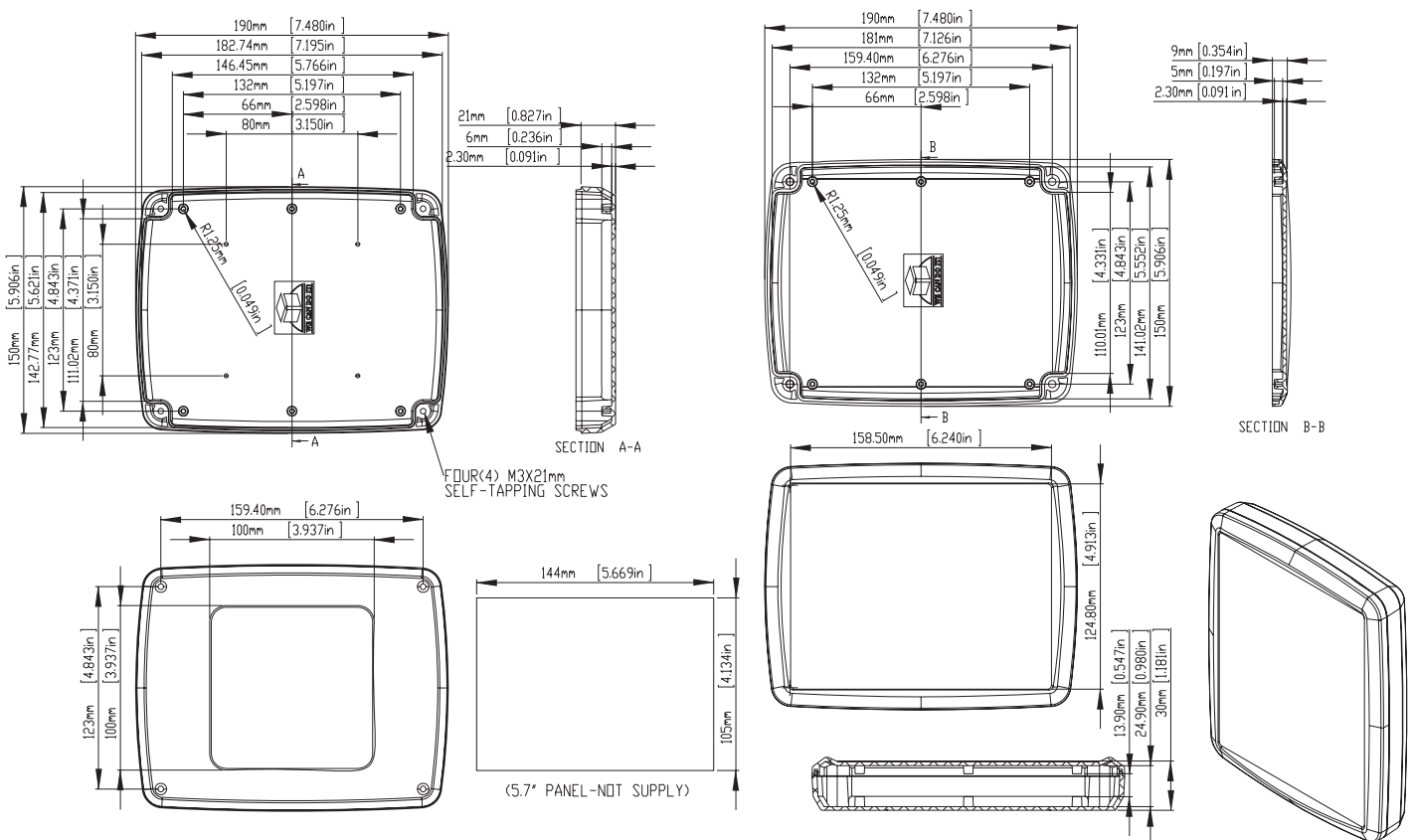

**PL2970WH / PL2970BK**

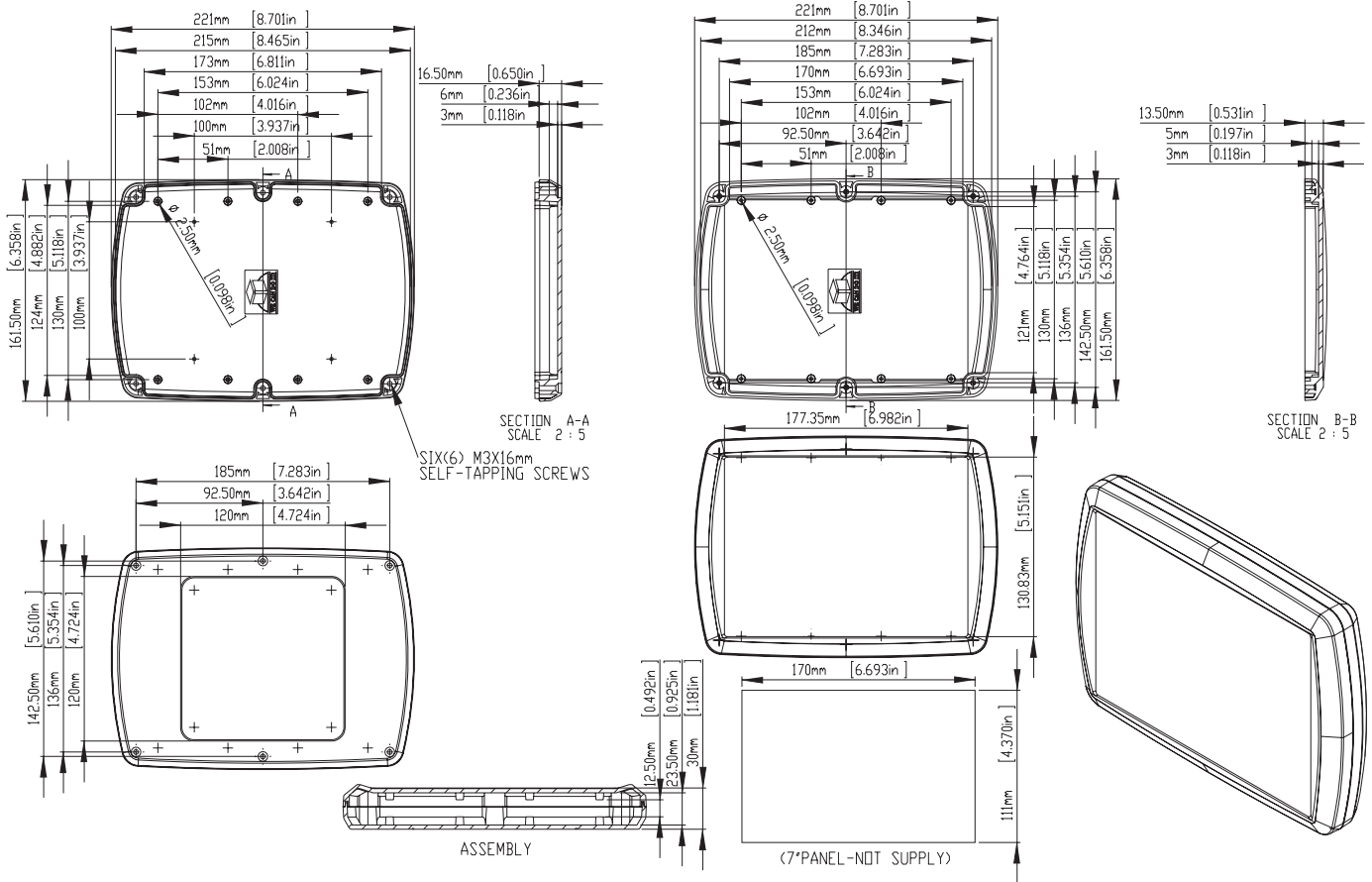

**PL2984WH / PL2984BK**

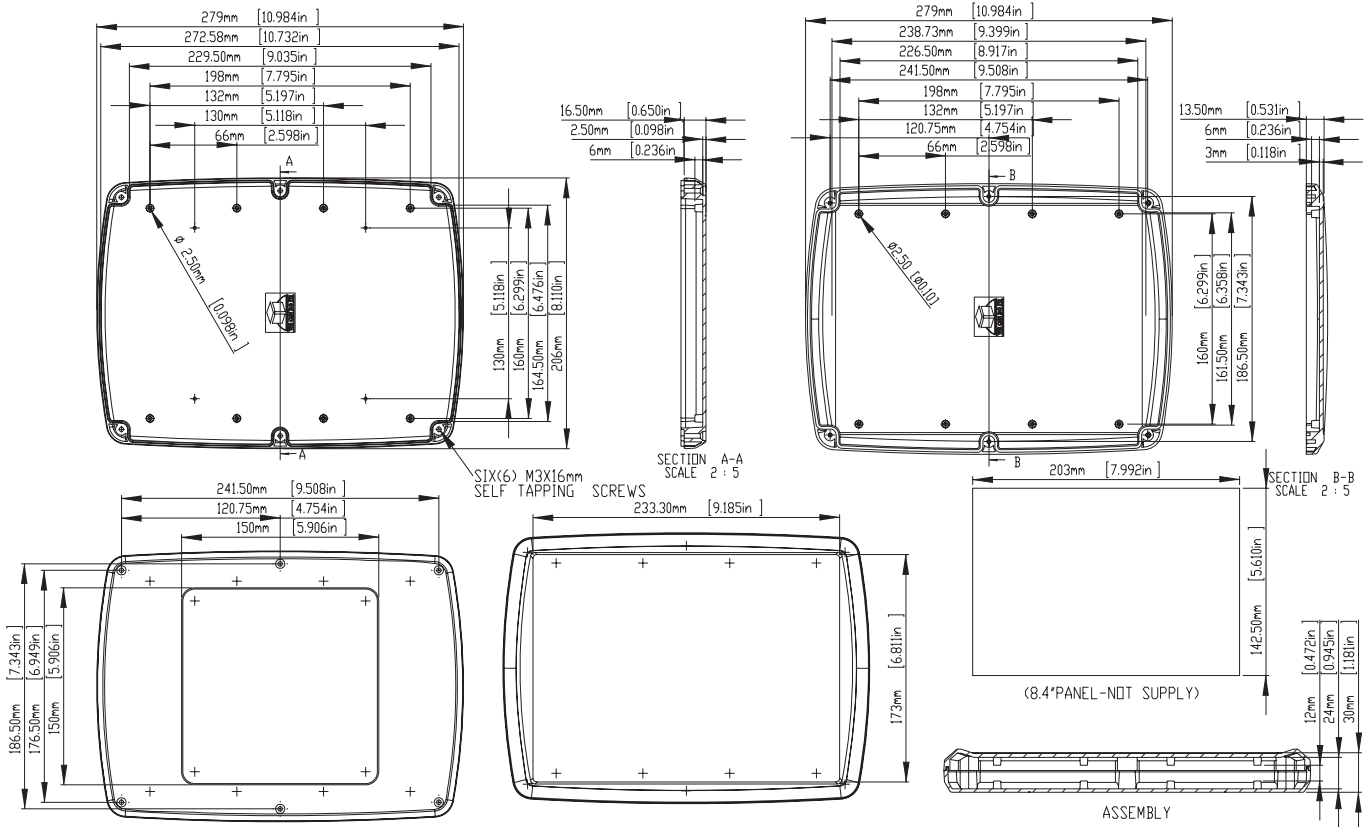

**PL29104WH / PL29104BK**

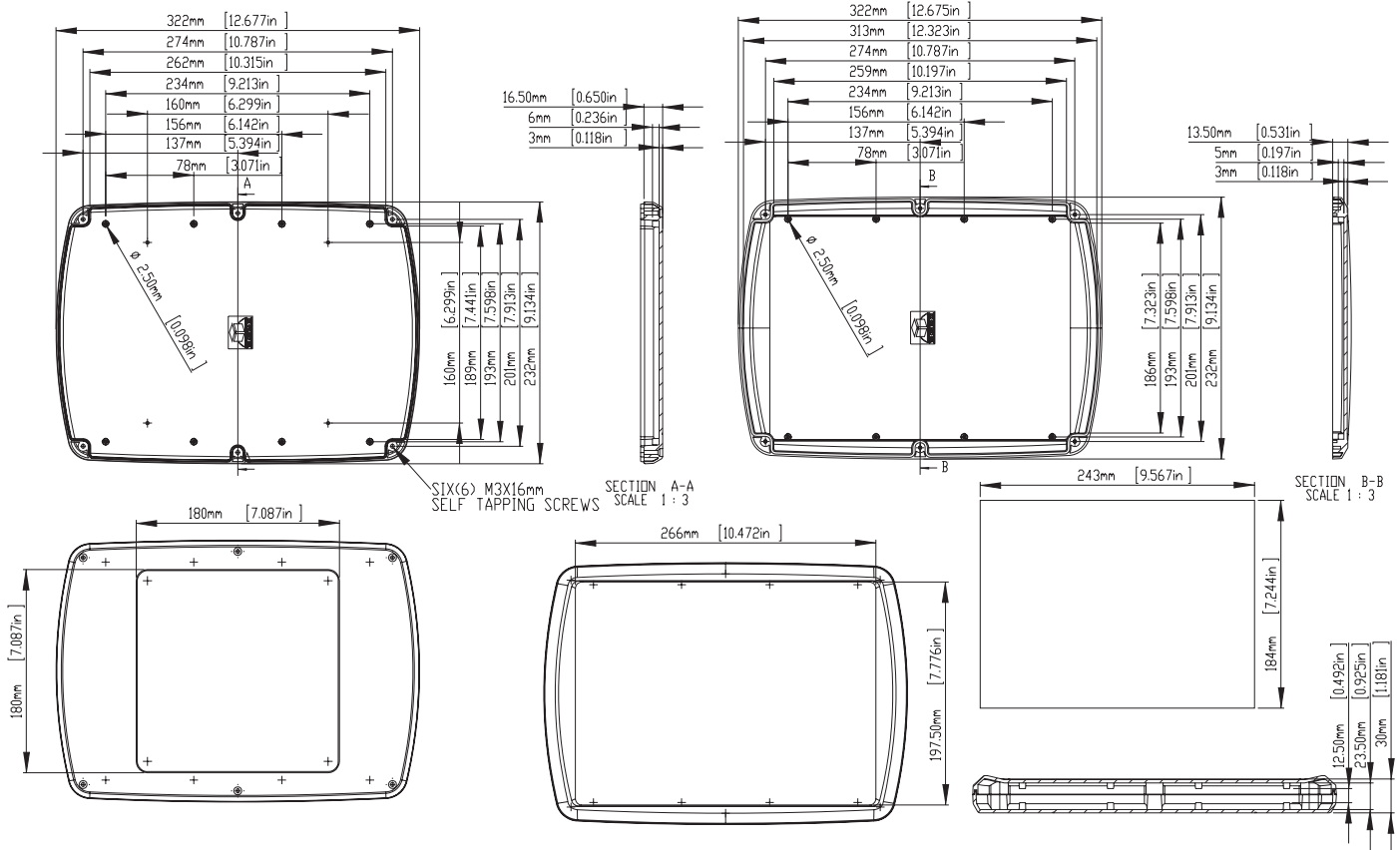

According to ISO 2768-m

Measuring DIM=L	Tolerances	Measuring DIM=L	Tolerances
0.5<L<=3.0mm	±0.1mm	30.0<L<=120.0 mm	±0.3mm
3.0<L<=6.0 mm	±0.1mm	120.0<L<=400.0 mm	±0.5mm
6.0<L<=30.0 mm	±0.2mm	400.0<L<=1000.0 mm	±0.8mm