



	DIN EN 61 558	VDE	on request
	DIN EN 60 335-1	VDE	on request
	UL 5085-3	UL	on request
	UL 5085-1	UL	on request
	C22.2	CSA	on request



- according to REACH regulation
- according to RoHs regulation

Technical Specifications

- Construction to DIN EN 61 558, DIN EN 60 950
- Creeping distance 4 mm min.
- 100 % unleaded
- UL listed materials
- Insulating material classification E (120 °C)
- Two outputs for connection in parallel or in series^(*)

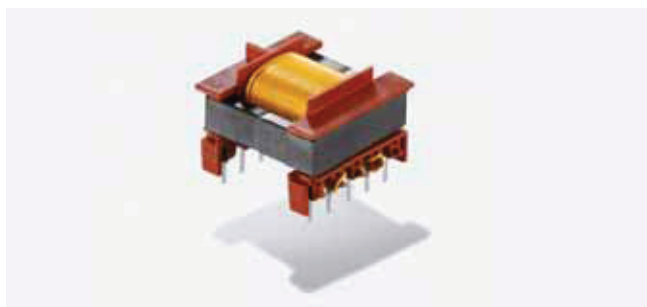
100 % piece inspection

- Inductance
- Turns ratio
- Winding direction
- Voltage resistance (50 Hz/1 s)

Connecting pins

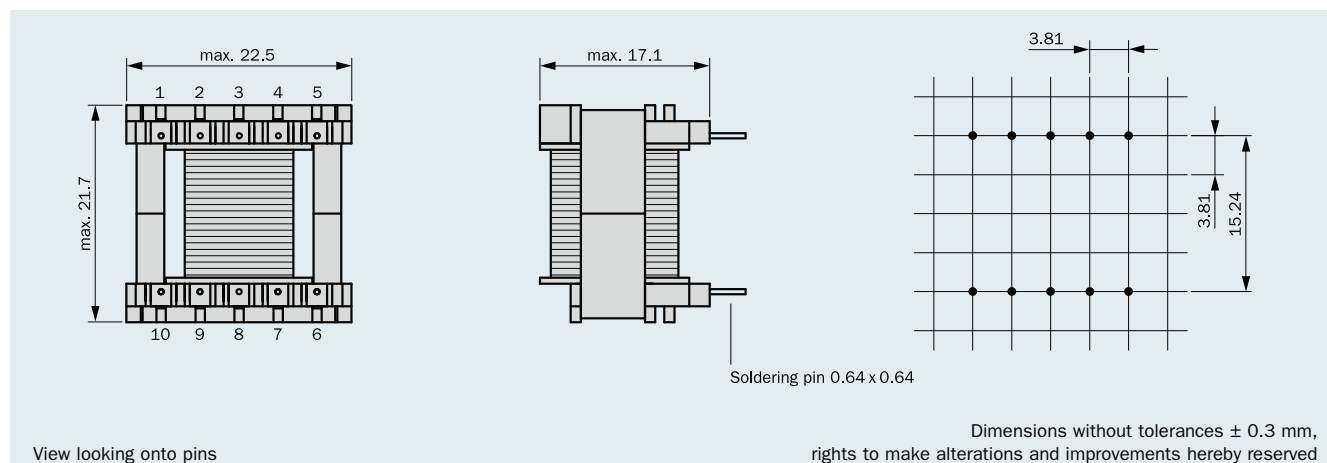

Connection scheme (only connected pins are present)

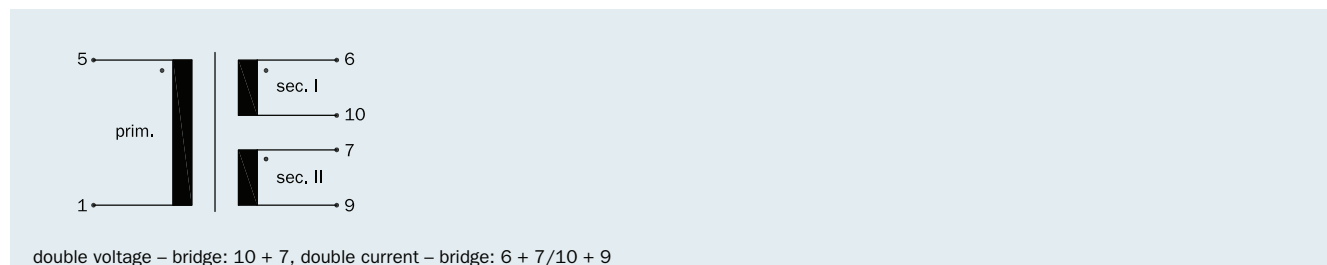



Flyback converters for Switch Mode Power Supplies

EF 20/6

Output Power: 8–16 W

8 W

**TinySwitch-II®
Product Family
TNY 267**

Order No.	Primary voltage V	Connecting pins prim.	Secondary voltage IV	Current sec. I mA	Connecting pins sec. I	Secondary voltage II V	Current sec. II mA	Connecting pins sec. II
V 50200*	85 – 265	1 – 5	3	1330	6 – 10	3	1330	7 – 9
V 50201*	85 – 265	1 – 5	9	440	6 – 10	9	440	7 – 9
V 50202*	85 – 265	1 – 5	12	330	6 – 10	12	330	7 – 9
V 50203*	85 – 265	1 – 5	15	270	6 – 10	15	270	7 – 9

* Two outputs for connection in parallel or in series

8 W

**TinySwitch-II®
Product Family
TNY 267**

Order No.	Primary voltage V	Connecting pins prim.	Secondary voltage IV	Current sec. I mA	Connecting pins sec. I	Secondary voltage II V	Current sec. II mA	Connecting pins sec. II
V 50204	85 – 265	1 – 5	12	640	6 – 7	3.3	100	9 – 10
V 50205	85 – 265	1 – 5	24	320	6 – 7	3.3	100	9 – 10
V 50206	85 – 265	1 – 5	12	625	6 – 7	5	100	9 – 10
V 50207	85 – 265	1 – 5	24	312	6 – 7	5	100	9 – 10

16 W

**TinySwitch-III®
Product Family
TNY 279**

Order No.	Primary voltage V	Connecting pins prim.	Secondary voltage IV	Current sec. I mA	Connecting pins sec. I	Secondary voltage II V	Current sec. II mA	Connecting pins sec. II
V 50210*	85 – 265	1 – 5	3	2670	6 – 10	3	2670	7 – 9
V 50211*	85 – 265	1 – 5	9	890	6 – 10	9	890	7 – 9
V 50212*	85 – 265	1 – 5	12	670	6 – 10	12	670	7 – 9
V 50213*	85 – 265	1 – 5	15	530	6 – 10	15	530	7 – 9

* Two outputs for connection in parallel or in series

16 W

**TinySwitch-III®
Product Family
TNY 278**

Order No.	Primary voltage V	Connecting pins prim.	Secondary voltage IV	Current sec. I mA	Connecting pins sec. I	Secondary voltage II V	Current sec. II mA	Connecting pins sec. II
V 50214	85 – 265	1 – 5	12	1300	6 – 7	3.3	100	9 – 10
V 50215	85 – 265	1 – 5	24	650	6 – 7	3.3	100	9 – 10
V 50216	85 – 265	1 – 5	12	1290	6 – 7	5	100	9 – 10
V 50217	85 – 265	1 – 5	24	645	6 – 7	5	100	9 – 10

