

103-H7123-1749

SANYO DENKI
SANMOTION

Dimensions (Unit:mm)

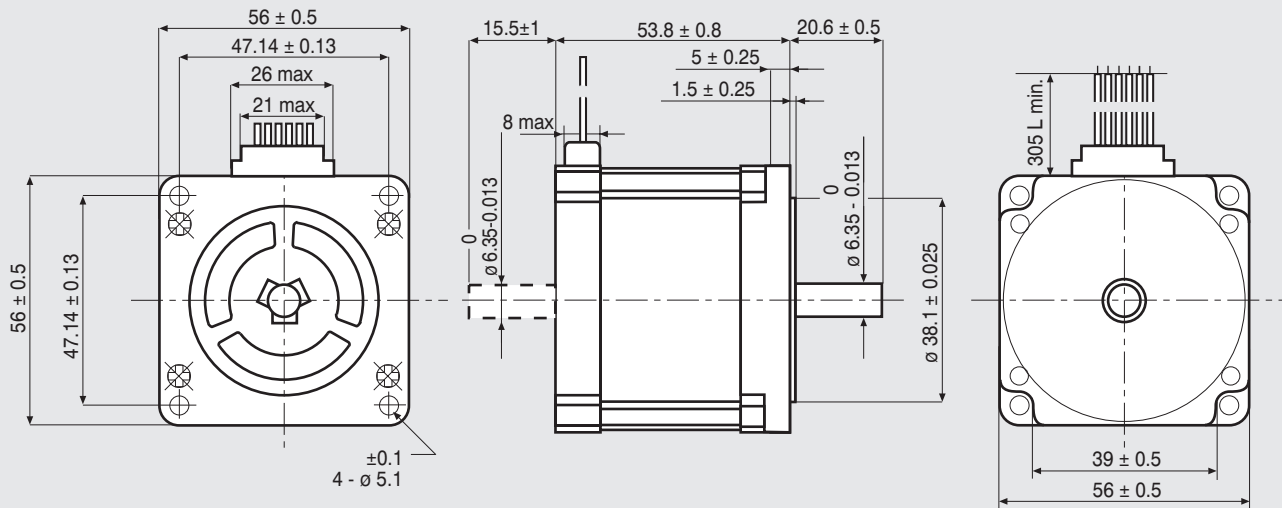

FEATURES

MODEL	103-H7123-1749 (103-H7123-1711)
BASIC STEP ANGLE	$1.8^\circ \pm 0.09^\circ$
BIPOLAR CURRENT (Amp)	4.0
UNIPOLAR CURRENT (Amp)	
RESISTANCE (Ohm)	0.41
INDUCTANCE (mH)	1.6
BIPOLAR HOLDING TORQUE (Ncm)	110
UNIPOLAR HOLDING TORQUE (Ncm)	
ROTOR INERTIA ($\text{Kg} \cdot \text{m}^2 \times 10^{-7}$)	210
THEORETICAL ACCELERATION ($\text{rad} \times \text{sec}^{-2}$)	50000
BACK E.M.F. (V/Krpm)	20
MASS (Kg)	0.65
LEADS CODE	V

Codes between brackets refer to double shaft models.
Le sigle fra parentesi si riferiscono ai modelli bialbero.

TORQUE/SPEED CURVE

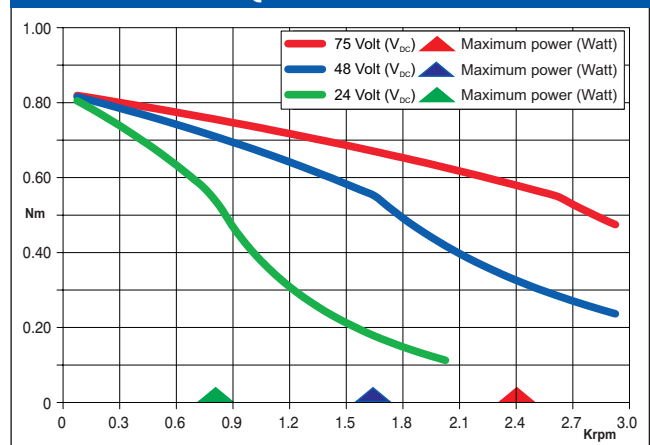

R.T.A. s.r.l. PAVIA (ITALY) SANYO DENKI CO., Ltd (JAPAN)

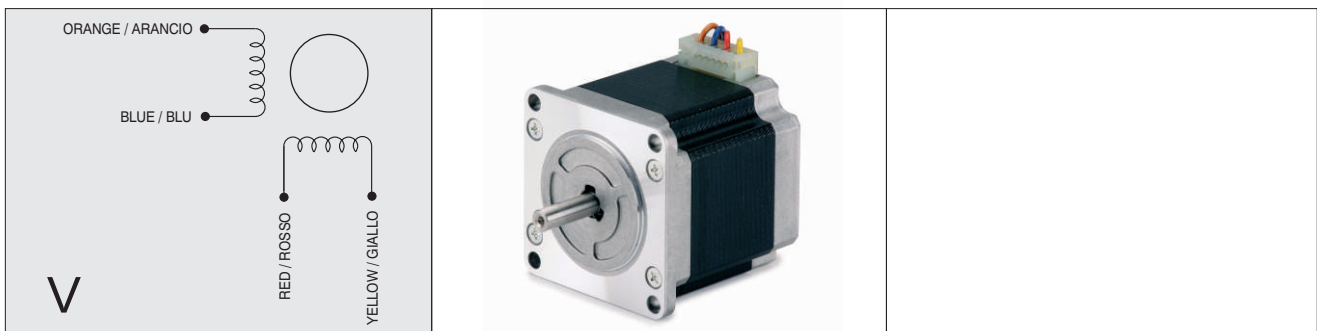

EIMC - 10 - 14

Suggested R.T.A. driver: CSD/CSD J/A-CSD Series, NDC/A-NDC Series, ADW Series, HGD Series, PLUS Series.



R.T.A. s.r.l.
Via E. Mattei - Fraz. Divisa
27020 MARCIGNAGO (PV) ITALY
Tel. +39.0382.929.855 - Fax +39.0382.929.150
www.rta.it

R.T.A. Deutschland GmbH
Bublitzer Straße 34
40599 DÜSSELDORF (Germany)
Tel. +49.211.749.668.60 - Fax +49.211.749.668.66
www.rta-deutschland.de

R.T.A. IBERICA-Motion Control Systems S.L.
C/Generalitat 22, 1º 3º
08850 GAVA - BARCELONA (Spain)
Tel. +34.936.388.805 - Fax +34.936.334.595
www.rta-iberica.es