

SM 2863-5155

SANYO DENKI
SANMOTION

Dimensions (Unit:mm)

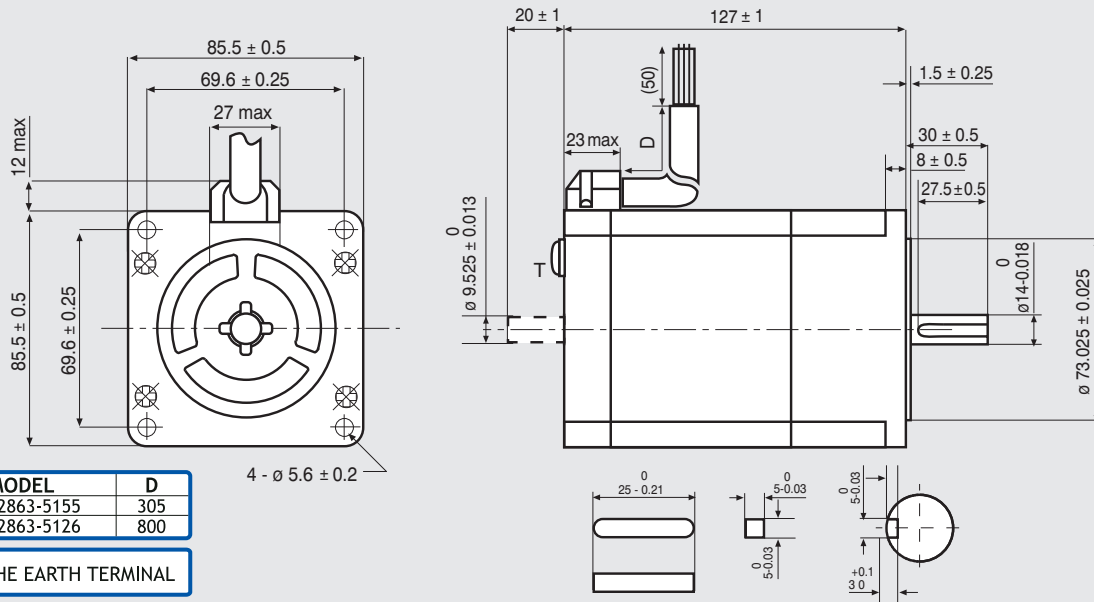

FEATURES

MODEL	SM 2863-5155 (SM 2863-5126)
BASIC STEP ANGLE	1.8° ± 0.09°
BIPOLAR CURRENT (Amp)	4.0
RESISTANCE (Ohm)	1.0
INDUCTANCE (mH)	7.9
BIPOLAR HOLDING TORQUE (Ncm)	920
ROTOR INERTIA (Kgm ² × 10 ⁻⁷)	4500
THEORETICAL ACCELERATION (rad × sec. ⁻²)	20500
BACK E.M.F. (V/Krpm)	241
MASS (Kg)	4
INTERNATIONAL STANDARDS	UL, CSA
INSULATION VOLTAGE (V)	250 V _{AC} (350 V _{DC})
PROTECTION DEGREE	IP43-F
LEADS CODE	V

Codes between brackets refer to double shaft models.
Le sigle fra parentesi si riferiscono ai modelli bialbero.

TORQUE/SPEED CURVE

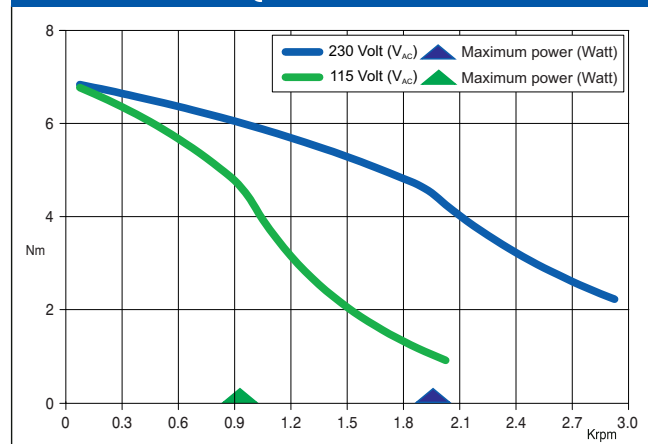

R.T.A. - s.r.l. PAVIA (ITALY) SANYO DENKI CO., Ltd (JAPAN)

ORANGE / ARANCIO

BLUE / BLU

RED / ROSSO

YELLOW / GIALLO

V

C **RU** **US**

PCD ∅ 34.2 ± 0.4

DOUBLE SHAFT MOTORS ONLY.
4 X M4 THREADED HOLES. TAP DEPTH 4.5 mm.

EMC - 10 - 14

Suggested R.T.A. driver: X-PLUS B Series, X-MIND Series.



R.T.A. s.r.l.
Via E. Mattei - Fraz. Divisa
27020 MARCIGNAGO (PV) ITALY
Tel. +39.0382.929.855 - Fax +39.0382.929.150
www.rta.it

R.T.A. Deutschland GmbH
Bublitz Straße 34
40599 DÜSSELDORF (Germany)
Tel. +49.211.749.668.60 - Fax +49.211.749.668.66
www.rta-deutschland.de

R.T.A. IBERICA-Motion Control Systems S.L.
C/Generalitat 22, 1° 3°
08850 GAVA - BARCELONA (Spain)
Tel. +34.936.388.805 - Fax +34.936.334.595
www.rta-iberica.es