

# ICS08 IO-Link 3-wire DC



## Miniaturized proximity inductive sensors with IO-Link communication



### Description

ICS08 series represents the optimal solution for industrial automation equipment in applications where space is limited, but long switching distance is needed, including tool-selection and textile machines. The advanced electronics is encapsulated in a robust stainless steel housing. The availability of the M8-plug and 2m-PVC cable connection in short or long housing construction allows flexible mounting.

On-board IO-Link communication opens up many possibilities, such as easy configuration and set-up of the devices and advanced parameter setting.

### Benefits

- **A complete family.** Available in M8 male thread robust stainless steel housings with an operating distance of 2 to 4 mm.
- **Easy to install.** Both flush and non-flush construction are available. The user can choose between short and long body housings in 2 m PVC cable or M8-disconnect plug versions.
- **High precision.** The onboard advanced microcontroller ensures better stability with respect to environmental influences, with highly repeatable measurements between -25 and +80°C.
- **Easy customization to specific OEM requests:** different cable lengths and materials, special labelling, customized pig-tail solutions with special cables and connectors are possible on request.
- **The output** can be operated either as a switching output or in IO-Link mode.
- **Fully configurable via IO-Link v1.1.** Electrical outputs can be configured as PNP/NPN/Push-pull, normally open or normally closed.
- **Timer functions** can be set, such as switch-on and switch-off delay
- **Adjustable sensing distance and hysteresis:** sensing distance can be set to 50% or 100% of the maximum sensing distance
- **Temperature monitoring:** over or under-run temperature alarms can be set



### Applications

- Non contact detection of metal objects in general position-sensing and presence-sensing in industrial applications
- Particularly suitable for rotational speed monitoring thanks to the high operating frequency

## Main functions

- Integrated diagnostic function with flashing LED in the event of a short circuit or overload
- The devices can be operated in IO-Link mode once connected to an IO-Link master, or in standard I/O mode.
- In IO-Link mode the switching signals of the sensor are made available in the process data via the IO-Link interface.
- Several sensor functions can be set via the IO-Link interface:
  - ▶ Adjustable switching distance: 50% or 100% of the maximum switching distance.
  - ▶ Adjustable hysteresis: standard or increased value.
  - ▶ Divider function: the sensor gives a signal after a specified number of actuation pulses has been reached.
  - ▶ Switch-on delay: the switching pulse is generated after the sensor actuation.
  - ▶ Switch-off delay: the generation of the switch signal is delayed by the set time after sensor actuation.
  - ▶ Temperature error: temperature is out of specifications.
  - ▶ Temperature over-run and under-run: temperature is out of the limits defined by the user.

## References

### Order code

 I C S 08     IO

Enter the code option instead of

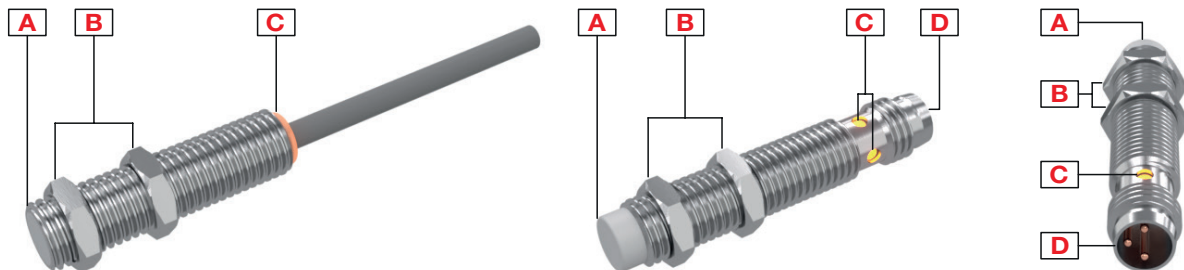
Code	Option	Description
I	-	Inductive sensor
C	-	Cylindrical housing with threaded barrel
S	-	Stainless steel housing
08	-	M8 housing
<input type="checkbox"/>	S30	Short housing with thread barrel of 30 mm
<input type="checkbox"/>	L45	Long housing with thread length of 45 mm
<input type="checkbox"/>	F	Flush
<input type="checkbox"/>	N	Non-flush
<input type="checkbox"/>	20	Sensing distance 2mm
<input type="checkbox"/>	40	Sensing distance 4mm
<input type="checkbox"/>	M5	M8 plug
<input type="checkbox"/>	A2	2 m PVC cable
IO	-	IO-Link programmable version

Additional characters can be used for customized versions.

**Selection guide**

Con- nec- tion	Body style	Dete- ction princi- ple	Rated operating distance Sn	Output type	Ordering no.
Cable Plug	Short	Flush	Configurable: 1 or 2mm <b>Factory setting: 2mm</b>	Configurable: NPN/PNP/ push-pull NO/NC <b>Factory setting: PNP, NO</b>	<b>ICS08S30F20A2IO</b>
		Non-flush	Configurable: 2 or 4mm <b>Factory setting: 4mm</b>		<b>ICS08S30F20M5IO</b>
Cable Plug	Long	Flush	Configurable: 1 or 2mm <b>Factory setting: 2mm</b>		<b>ICS08S30N40A2IO</b>
		Non-flush	Configurable: 2 or 4mm <b>Factory setting: 4mm</b>		<b>ICS08S30N40M5IO</b>
Cable Plug	Long	Flush	Configurable: 1 or 2mm <b>Factory setting: 2mm</b>		<b>ICS08L45F20A2IO</b>
		Non-flush	Configurable: 2 or 4mm <b>Factory setting: 4mm</b>		<b>ICS08L45F20M5IO</b>
Cable Plug	Long	Flush	Configurable: 1 or 2mm <b>Factory setting: 2mm</b>		<b>ICS08L45N40A2IO</b>
		Non-flush	Configurable: 2 or 4mm <b>Factory setting: 4mm</b>		<b>ICS08L45N40M5IO</b>

## Structure

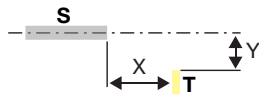


Element	Component	Function
A	Sensing face	Flush or non-flush
B	2 nuts	For sensor mounting
C	LED	Yellow LED: Output flashing: short circuit or overload indication
D	M8, 3 pin, male connector	For plug versions only

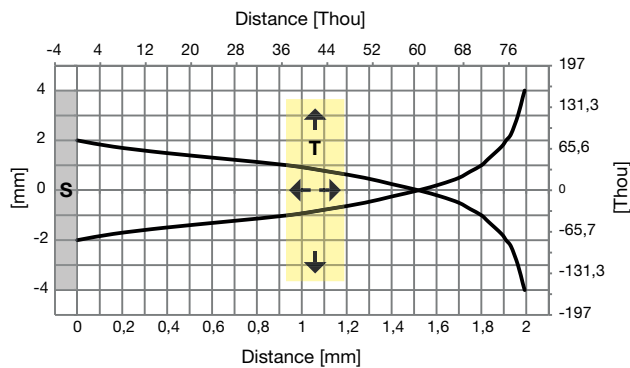
# Sensing

## Detection

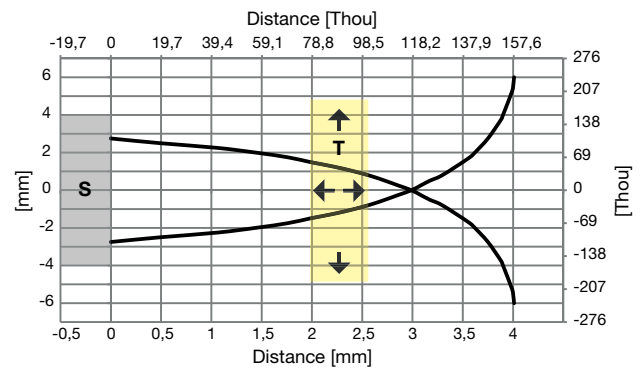
<b>Rated operating distance <math>S_n</math></b>	2 mm flush or 4 mm non-flush Programmable via IO-Link: 50% or 100% of the maximum $S_n$
<b>Reference target</b>	The operating distance is measured according to IEC 60947-5-2, using a standard target moving axially. This target is square shape 1 mm thickness, made of steel e.g. type Fe 360 as defined in ISO 630 and it shall be of the rolled finish. The length of the side of the square is equal to – the diameter of the circle inscribed on the active surface of the sensing face, or – three times the rated operating distance $S_n$ whichever is greater
<b>Assured operating sensing distance (<math>S_a</math>)</b>	$0 \leq S_a \leq 0.81 \times S_n$ (e.g. with $S_n$ of 2 mm, $S_a$ is 0 ... 1.62 mm)
<b>Effective operating distance (<math>S_r</math>)</b>	$0.9 \times S_n \leq S_r \leq 1.1 \times S_n$
<b>Usable operating distance (<math>S_u</math>)</b>	$0.9 \times S_r \leq S_u \leq 1.1 \times S_r$
<b>Temperature drift</b>	$\leq \pm 10\%$
<b>Hysteresis (H)</b>	Programmable via IO-Link: standard or increased



**S:** sensor  
**T:** target



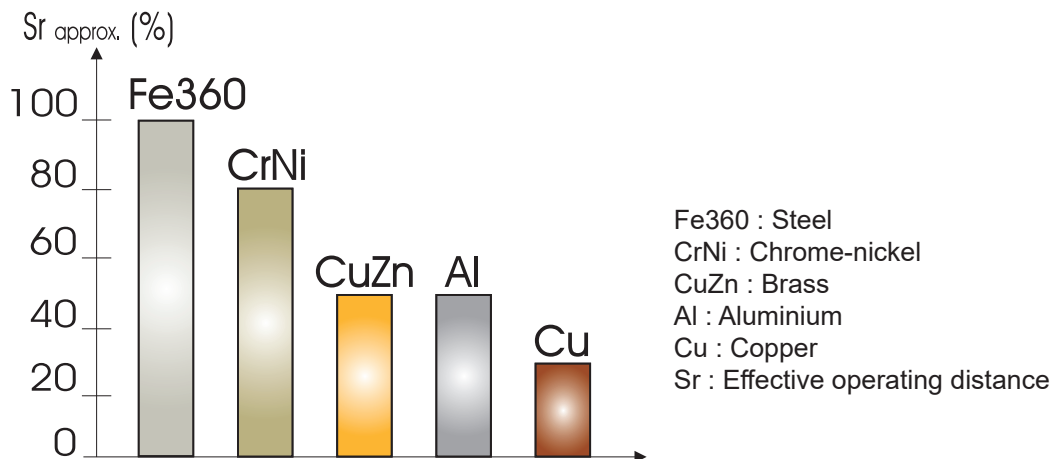
**Fig. 1 Flush**



**Fig. 2 Non-flush**

### Correction factors

The specific operating distance  $S_n$  refers to defined measuring conditions. The following data have to be considered as general guidelines.



**Fig. 3** The rated operating distance is reduced by the use of metals and alloys other than Fe360. The most important reduction factors for inductive proximity sensors are shown in the figure.

### Accuracy

Repeat accuracy (R)	≤ 5%
---------------------	------

## Features

### Power Supply

Rated operational voltage ( $U_b$ )	10 to 30 VDC (ripple included)
Ripple ( $U_{rpp}$ )	≤ 10%
No load supply current ( $I_o$ )	≤ 17 mA
Power ON delay ( $t_v$ )	≤ 50 ms

## Outputs

<b>Output functions</b>	Configurable via IO-Link: PNP, NPN or push-pull Factory setting: PNP
<b>Output configuration</b>	Configurable via IO-Link: N.O. or N.C. Factory setting: N.O.
<b>Output current (<math>I_o</math>)</b>	$\leq 100$ mA
<b>OFF-state current (<math>I_r</math>) (only for PNP or NPN output)</b>	$\leq 100$ $\mu$ A
<b>Voltage drop (<math>U_d</math>)</b>	Max. 1.2 VDC @ 100 mA
<b>Protection</b>	Short-circuit, reverse polarity and transients
<b>Voltage transient</b>	1 kV/0.5 J

## Response times

<b>Operating frequency (f)</b>	$\leq 2$ KHz
--------------------------------	--------------

## Indication

### Standard IO mode:

Yellow LED	Output	Description
OFF	OFF	N.O. output, target not present N.C. output, target present
ON	ON	N.O. output, target present N.C. output, target not present
Blinking	f: 2Hz	Short-circuit or overload
	f: 1Hz	Temperature alarm (if enabled)





### IO-Link mode:

- LED is ON for 0.75 s and OFF for 0.075 s
- Possibility to disable the LED

## Environmental

<b>Ambient temperature</b>	Operating: -25° to +80°C (-13° to +176°F)	
	Storage: -30° to +80°C (-22° to +176°F)	
<b>Ambient humidity</b>	Operating: 35% to 95%	
	Storage: 35% to 95%	
<b>Vibration</b>	10 to 55 Hz, amplitude 1.0 mm; sweep cycle 5 min; in X, Y and Z direction	IEC 60068-2-6
<b>Shock</b>	30 G /11 ms. 10 shocks in X, Y and Z direction	IEC 60068-2-27
<b>Degree of protection</b>	IP67	IEC 60529; EN 60947-1

### Compatibility and conformity

EMC protection	IEC 61000-4-2 Electrostatic discharge	8 kV air discharge 4 kV contact discharge
	IEC 61000-4-3 Radiated radiofrequency	3 V/m
	IEC 61000-4-4 Burst immunity	2 kV
	IEC 61000-4-6 Conducted radio frequency	3 V
	IEC 61000-4-8 Power frequency magnetic fields	30 A/m
MTTF <sub>d</sub>	4513 years @ 50°C (122°F)	
Approvals	    <b>IO-Link</b>	
	CCC is not required for products rated ≤ 36 V	

### Mechanical data

Weight (including 2 nuts and the packaging) max.	Cable version: short, flush: 44.8g; short, non-flush: 44.9g; long, flush: 47g; long, non-flush: 47.1g; Plug version: short, flush: 16g; short, non-flush: 16.1g; long, flush: 18.4g; long, non-flush: 18.5g.
Mounting	Flush mountable or non-flush mountable
Material	Housing: stainless steel AISI304 Front cap: Grey thermoplastic polyester
Max tightening torque	7 Nm

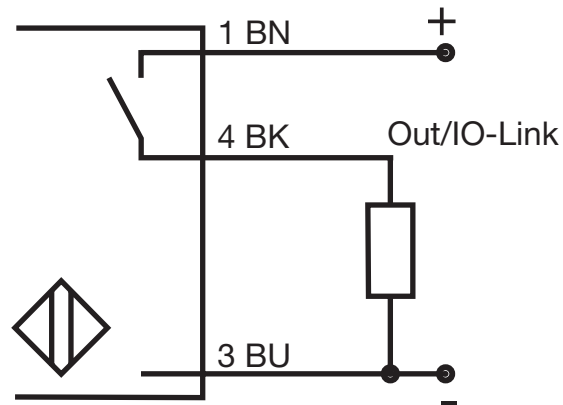
### Electrical connection

Cable	2m, 3 x 0.14 mm <sup>2</sup> , Ø3.2 mm, PVC, grey, oil proof
Plug	M8 x 1 quick disconnect, 3 pin, male connector

### Communication

Communication	Via IO-Link V1.1 or via standard I/O
---------------	--------------------------------------

## Connection Diagrams

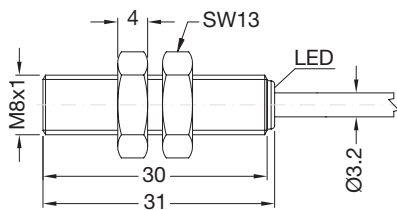


Colour code		
<b>BN:</b> brown	<b>BK:</b> black	<b>BU:</b> blue

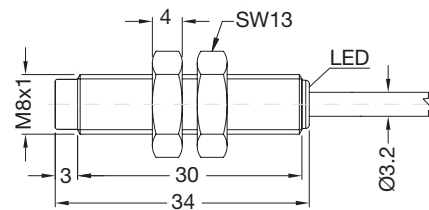


# Dimensions [mm]

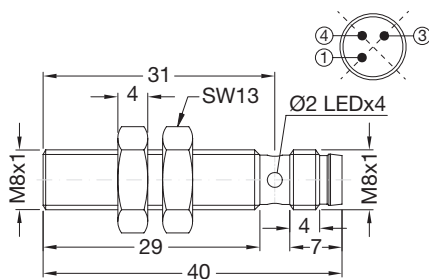
## ICS08 [mm]



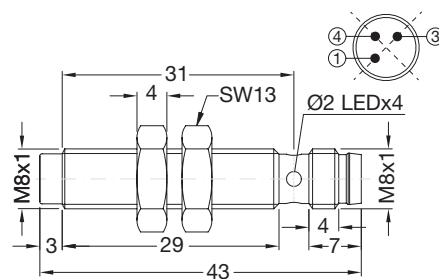
**Fig. 4** Short body, flush version, cable



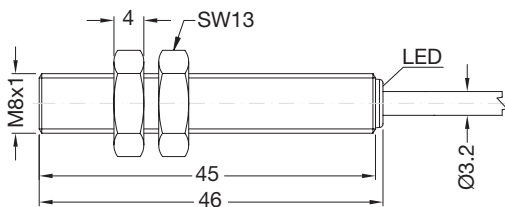
**Fig. 5** Short body, non-flush version, cable



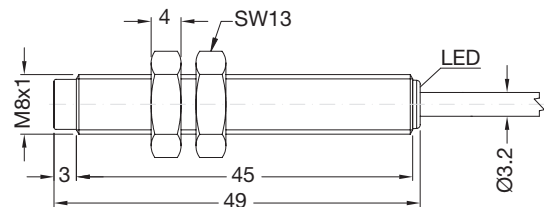
**Fig. 6** Short body, flush version, plug



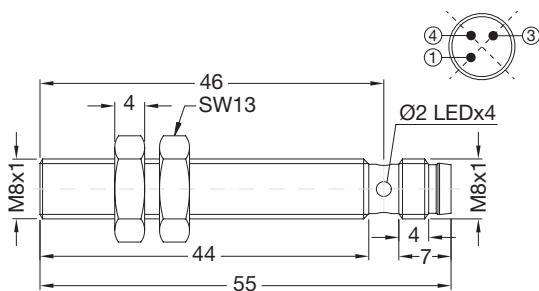
**Fig. 7** Short body, non-flush version, plug



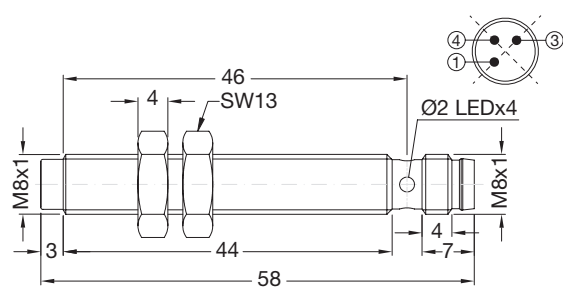
**Fig. 8** Long body, flush version, cable



**Fig. 9** Long body, non-flush version, cable



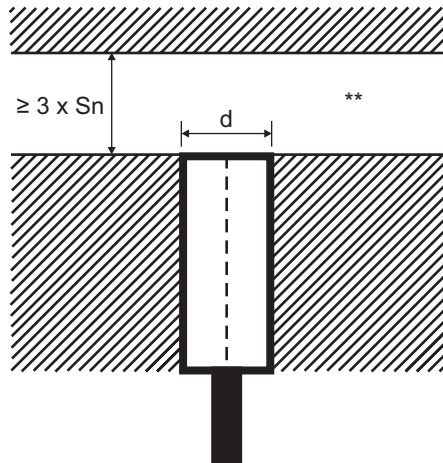
**Fig. 10** Long body, flush version, plug



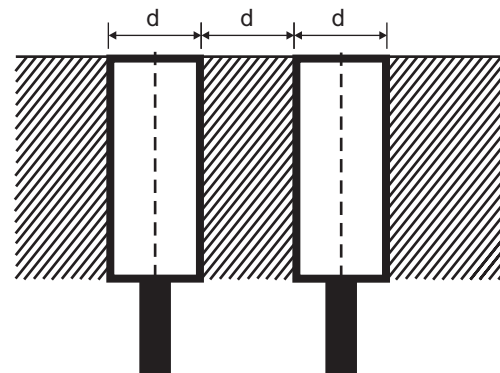
**Fig. 11** Long body, non-flush version, plug

## Installation

### M8 flush

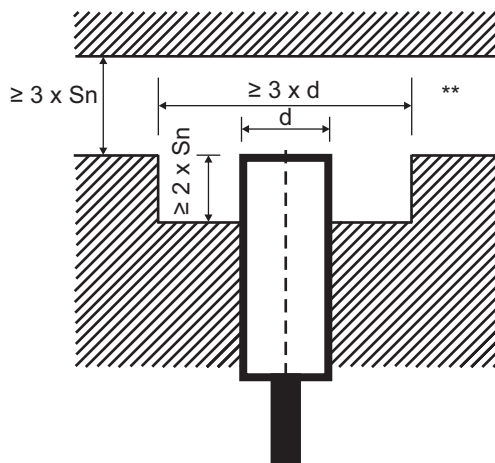


**Fig. 12** Flush sensor, when installed in damping material

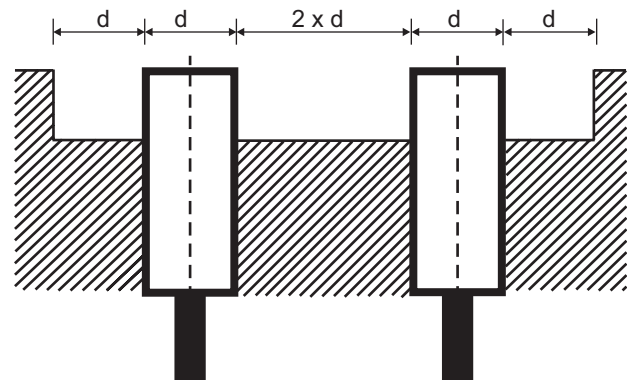


**Fig. 13** Flush sensors, when installed together in damping material

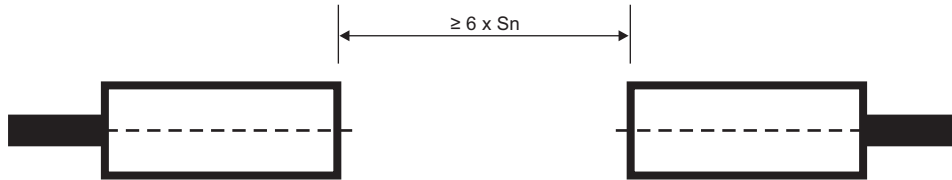
### M8 non-flush



**Fig. 14** Non-flush sensor, when installed in damping material



**Fig. 15** Non-flush sensors, when installed together in damping material

**Sensors installed opposite each other**

**Fig. 16** For sensors installed opposite each other, a minimum space of  $6 \times S_n$  (the nominal sensing distance) must be observed

\*\* Free zone or non-damping material

$S_n$ : nominal sensing distance

d: sensor diameter: 8 mm



## Delivery contents and compatible components




### Delivery contents

- Inductive proximity switch
- 2 fixing nuts
- 2 lock washers
- Packaging: plastic bag

### CARLO GAVAZZI compatible components

- Mounting bracket AMB8... to be purchased separately
- Connector type: CONB53... series to be purchased separately

### Further reading

Information	Where to find it	QR
IO-Link manual	<a href="http://www.productselection.net/MANUALS/UK/IOL_IM.pdf">http://www.productselection.net/MANUALS/UK/IOL_IM.pdf</a>	
Mounting brackets	<a href="http://www.productselection.net/Pdf/UK/AMB8_30.pdf">http://www.productselection.net/Pdf/UK/AMB8_30.pdf</a>	
Connectors	<a href="http://www.productselection.net/Pdf/UK/CONB5.pdf">http://www.productselection.net/Pdf/UK/CONB5.pdf</a>	



COPYRIGHT ©2020  
Content subject to change. Download the PDF: [www.gavazziautomation.com](http://www.gavazziautomation.com)